

Technical parameters

Model	IR-Plate
Wavelength, nm	940±20
Illumination range (see n. Product purpose), m	3,5
Viewing angle, $2\theta_{0,5}$, °	160±10
Continuous current, A	0,5max
Input voltage, V	12±0,6
Operating temperature, °C	-30... +40
Dimensions, mm	106x72x6
Weight, kg	0,1
Protection Standard	IP65

Product purpose.

The IR-illuminator is designed for the covert illumination of the observed object in the conditions of insufficient illuminance.



Warning!
Dissolvents and chemical reagents are never allowed for cleaning!

Storage requirements.

The illuminator should be stored in the closed space without aggressive environment in the form of acid vapors and alkali mist. The ambient air temperature should be from -50°C to +50°C; the air relative humidity should not be above 95% at the temperature of 25°C.

Warranty.

The producer or the supplier guarantees the conformity of the "IR-Plate-940" illuminator to the technical requirements provided the user observes the storage and operation rules stated in the instruction manual. The warranty period is 36 months from the date of sale. The warranty validity terminates in case the user does not observe the storage or operation rules or in case of the breach of the case integrity or voluntary repair, product conversion, modernization etc.

The distance of the illumination is indicated for the black and white videocamera without IR correction featured with the 1/3" matrix the sensitivity of which is no worse than $1,5 \cdot 10^{-5}$ W/m² in the IR band of 0,8...1 μm (the equivalent of the videocamera with the sensitivity of 0,01 lx), the objective is F1.4. The illuminator can be installed either outdoors or indoors. During the installation it is necessary to provide free circulation of the ambient air round the case of the illuminator for cooling.

Set of delivery.

IR illuminator – 1 pc, packing – 1 pc, instruction manual – 1 pc.

The device design.

IR illuminator contains a LED (Light Emitting Diode)-matrix based on luminodiodes with the built in forming optics. Constructively the illuminator is made of aluminum alloy. The LEDs are installed on the front side of the case, they are covered with the light filter made of special plastic.

Certificate of acceptance.

ID number _____

The illuminator passed the engineering control test and is considered to be in operational condition.

ECD(Engineering Control Department) Stamp

Date of the test _____

Trade organization _____
(Place for stamp)

Date of sale _____

Signature of the buyer _____

Inscription location.

It is allowed to place inscriptions and stickers on the front side of the light filter while the LED-matrix and camera location areas should not be obstructed (see diagram 1).

Safety measures.

This IR illuminator complies with EN60065:2001+Amd1:Audio, Video & similar electronic apparatus: Safety requirements and Maximum Permissible Exposure limits of IEC60825-1. This product conforms to EMC Directive 89/336/EEC as amended by 92/31/EEC and 93/68/EEC.



Caution! Invisible LED radiation!

Do not view directly with optical instruments (magnifiers). CLASS 1M LED product.

It is necessary to observe the polarity of the power supply connection: - (+) red, (-) black. It is forbidden to use the illuminator with the parameters exceeding the maximal permitted values.

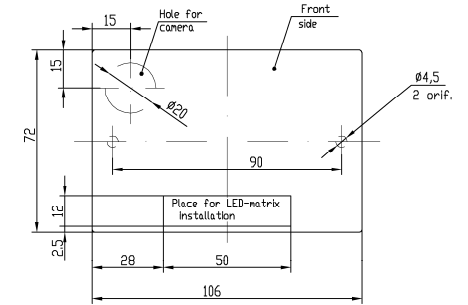

Diagram 1. The location areas of the LED-matrix and camera.

Maintenance.

During the illuminator operation it is required to clean the protective light filter when it becomes dirty. The light filter cleaning is done with the help of a wet cotton cloth with the continuous change of the cloth contacting surface in order to avoid damage of the light filter surface by abrasive material.

infrared illuminators
MICROLIGHT



Manufactured by MicroLight Co., Ltd.

INFRARED ILLUMINATOR
IR-Plate-940

Instruction manual



Warning!

Dissolvents and chemical reagents are never allowed for cleaning!

Storage rules.

The illuminator should be stored in the closed space without corrosive medium in form of vapor and acids and alkali mist. The ambient air temperature should be from -50°C to $+50^{\circ}\text{C}$; the air relative humidity should not be above 95% at the temperature of 25°C .

Warranty.

The producer or the supplier guarantees the conformity of the "IR-Plate-940" illuminator to the technical requirements provided the user observes the storage and operation rules stated in the instruction manual. The warranty period is 36 months from the date of sale. The warranty validity terminates in case the user does not observe the storage or operation rules or in case of the breach of the case integrity or voluntary repair, product conversion, modernization etc.

Technical parameters

Model	IR-Plate
Wavelength, nm	940±20
Illumination range (see n. Product purpose), m	3,5
Viewing angle, $2\theta_{0,5}$, °	160±10
Continuous current, A	0,5max
Input voltage, V	12±0,6
Operating temperature, °C	-30... +40
Dimensions, mm	106x72x6
Weight, kg	0,1
Protection Standard	IP65

Product purpose.

The IR-illuminator is designed for the covert illumination of the observed object in the conditions of insufficient illuminance.

Certificate of acceptance.

ID number _____

The illuminator passed the engineering control test and is considered to be in operational condition.

ECD(Engineering Control Department) Stamp

Date of the test _____

Trade organization _____
(Place for stamp)

Date of sale _____

Signature of the buyer _____



Manufactured by MicroLight Co., Ltd.

infrared illuminators
MICROLIGHT



INFRARED ILLUMINATOR
IR-Plate-940

Instruction manual

The distance of the illumination is indicated for the black and white videocamera without IR correction featured with the 1/3" matrix the sensitivity of which is no worse than $1,5 \cdot 10^{-5}$ W/m² in the IR band of 0,8...1 μm (the equivalent of the videocamera with the sensitivity of 0,01 lx), the objective is F1.4. The illuminator can be installed either outdoors or indoors. During the installation it is necessary to provide free circulation of the ambient air round the case of the illuminator for cooling.

Set of delivery.

IR illuminator – 1 pc, packing – 1 pc, instruction manual – 1 pc.

The device design.

IR illuminator contains a LED (Light Emitting Diode)-matrix based on luminodiodes with built in forming optics. Constructively the illuminator is made of aluminum alloy. The LEDs are installed on the front side of the case, they are covered with the light filter made of special plastic.

Inscription location.

It is allowed to place inscriptions and stickers on the front side of the light filter while the LED-matrix and camera location areas should not be obstructed (see diagram 1).

Safety measures.

This IR illuminator complies with EN60065:2001+Amd1:Audio, Video & similar electronic apparatus: Safety requirements and Maximum Permissible Exposure limits of IEC60825-1. This product conforms to EMC Directive 89/336/EEC as amended by 92/31/EEC and 93/68/EEC.



Caution! Invisible LED radiation!

Do not view directly with optical instruments (magnifiers). CLASS 1M LED product.

It is necessary to observe the polarity of the power supply connection: - (+) red, (-) black. It is forbidden to use the illuminator with the parameters exceeding the maximal permitted values.

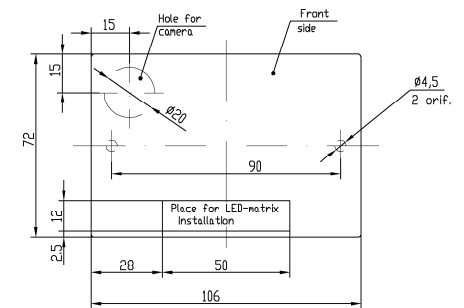

Diagram 1. The location areas of the LED-matrix and camera.

Maintenance.

During the illuminator operation it is required to clean the protective light filter when it becomes dirty.

The light filter cleaning is done with the help of a wet cotton cloth with the continuous change of the cloth contacting surface in order to avoid damage of the light filter surface by abrasive material.